

Special Features

- ▲ VANDAL RESISTANT DESIGN
- ▲ HYGIENIC ONE PIECE CONSTRUCTION
- ▲ INTEGRAL RETURN ENDS FOR WALL OR FREE STANDING INSTALLATIONS
- ▲ CONCEALED SPARGE PIPES
- ▲ COMPLETE WITH FLUSHPIPE AND CISTERN
- ▲ EASILY AND QUICKLY INSTALLED AT ADULT OR JUNIOR HEIGHT
- ▲ COMPETITIVELY PRICED
- ▲ OPTIONAL WHITE **Enviro-Glaze** FINISH

Description

The trough urinal can be wall mounted at adult or junior height leaving the floor clear for ease of cleaning and hygiene. The wall hung urinal is economically priced, easy to install and is available in a range of standard lengths.

Construction

The urinal is manufactured in one piece without joints or crevices from grade 304 stainless steel, with all exposed surfaces polished to a satin finish.

The requisite fall to a central outlet is built into the channel and the back of the urinal is designed to ensure an efficient spread of flushing water without drips or splashing. The urinal back panel is sound deadened to eliminate drumming. Available in five standard lengths, all urinals incorporate a concealed sparge system and integral return ends for either wall or free standing installations.

Each urinal is supplied with a dome grated waste fitting and automatic cistern and flushpipe.

Options

- ▲ Stainless steel automatic cistern (see catalogue section 1 - product code 131).
- ▲ White **Enviro-Glaze** finish.



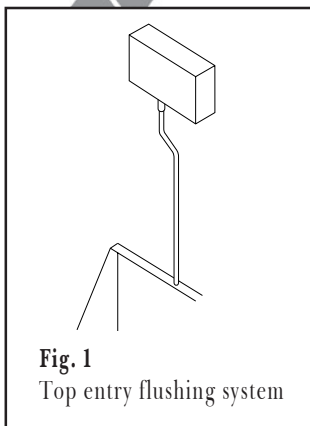
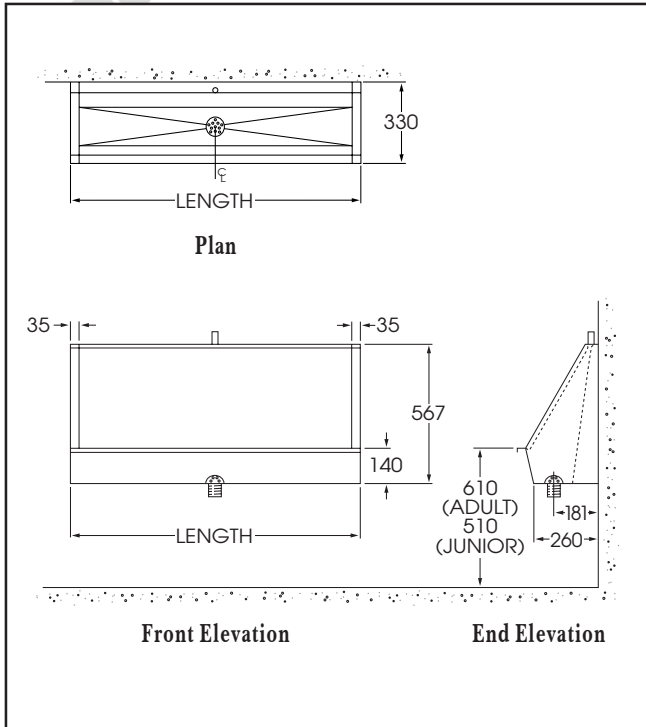

Length

The urinal is available in five standard lengths; 1200 mm, 1500 mm, 1800 mm, 2100 mm and 2400 mm. Lengths over 2400 mm supplied as multiple units with joint cover trim for abutting ends.

Waste Outlet

All urinals are supplied with a 50 mm (2 in) BSP dome grated waste fitting positioned centrally.

Flushing System

All urinals are fitted with a sparge system concealed within the units' construction. The sparge system connection to the flushpipe is top entry for an exposed surface mounted cistern (see Fig. 1). By using an elbow fitting the sparge system connection can be easily converted to back entry for a concealed duct mounted cistern.

Flushpipe

Urinals are supplied with 22 mm diameter stainless steel flushpipes and wall fixing clips. The length of each flushpipe allows for its cistern to be mounted at the maximum recommended height.

Cistern

All urinals are supplied with plastic or optional stainless steel automatic flushing cisterns. Each cistern is complete with lid, syphon and petcock. The recommended mounting height is 1800 mm minimum to 2000 mm maximum from the underside of the cistern to finished floor level.

Cistern Capacity

Urinal Length	-1200mm	-1500-2400mm
Cisterns	-1 x 9.0 litre	-1 x 13.65 litre

Product Code Selection for Order or Quotation

1. Base Product Code

064-wall hung trough urinal

2. Length

- 1200 -2100
-1500 -2400
-1800

3. Outlet (as facing)

-C-central

4. Flushing System

-TE-top entry

5. Options

- 131-stainless steel cistern
-JT-joint cover trim
-WG-white **Enviro-Glaze**